

#### IV. Summary

The  $-M/N$  ratios of allene, methylacetylene, dimethylacetylene, butene and isoprene have been determined.

With the exception of isoprene the values are constant throughout the course of the reaction.

These ratios are shown to be additive and constitutive.

The lower the ratio  $\frac{\Delta(H_2 + CH_4)}{-\Delta H.C.}$ , the higher is the  $-M/N$  ratio.

The values of the  $-M/N$  ratios are not incompatible with the ion cluster theory.

MINNEAPOLIS, MINNESOTA

PRINCETON, NEW JERSEY

---

[CONTRIBUTION FROM THE DEPARTMENT OF CHEMISTRY, CORNELL UNIVERSITY]

### THE PREPARATION OF FLUORINE BY ELECTROLYSIS

BY L. M. DENNIS, J. M. VEEDER AND E. G. ROCHOW

RECEIVED JUNE 13, 1931

PUBLISHED SEPTEMBER 5, 1931

The preparation of fluorine by electrolysis of molten potassium hydrogen fluoride ( $KF \cdot HF$ ) was first described by Argo, Mathers, Humiston and Anderson.<sup>1</sup> They first employed a cell of copper, later of graphite, with a graphite anode.

Meyer and Sandow<sup>2</sup> modified the apparatus, giving it a more complicated form without materially improving its operation. Simons reverted<sup>3</sup> to a copper cell patterned after that of Argo.<sup>1</sup> A cell of magnesium was later designed by Mathers and was used by Jones,<sup>4</sup> and recently magnesium has been replaced by monel metal.<sup>5</sup>

The descriptions of these various cells for the electrolysis of molten potassium hydrogen fluoride, as well as private communications from the users, bring out certain difficulties in their construction and operation, such as the designing of a suitable diaphragm, fracture of the cell if the electrolyte is allowed to cool and solidify in it, plugging of the delivery tube,<sup>2,3,4</sup> with resultant explosion due to the forcing of fluorine into the cathode chamber,<sup>2</sup> inconvenience of removal of the electrolyte for replacement by a fresh charge,<sup>1,2,3,5</sup> foaming of the electrolyte,<sup>1,2,3</sup> long preliminary electrolysis before fluorine is evolved ("two hours," "eight hours," "several hours"), sudden cessation of the evolution of fluorine,<sup>6</sup> sealing in the anode rod in durable and satisfactory manner.

<sup>1</sup> Argo, Mathers, Humiston and Anderson, *J. Phys. Chem.*, **23**, 348 (1919); *Trans. Am. Electrochem. Soc.*, **35**, 335 (1919); see also Mathers, *ibid.*, **36**, 207 (1919).

<sup>2</sup> Meyer and Sandow, *Ber.*, **54**, 759 (1921).

<sup>3</sup> Simons, *THIS JOURNAL*, **46**, 2175 (1924).

<sup>4</sup> Jones, *J. Phys. Chem.*, **33**, 801 (1929).

<sup>5</sup> Schumb and Gamble, *THIS JOURNAL*, **52**, 4302 (1930).

<sup>6</sup> Private communications.

Furthermore, while nearly all of the authors cited above used sodium fluoride to remove hydrogen fluoride from the evolved fluorine and state that the removal is complete,<sup>2,3,7</sup> it appears that none of them subjected the point to experimental test, but merely accepted the statement of Moissan,<sup>8</sup> who also apparently did not experimentally ascertain its accuracy. If the removal of hydrogen fluoride by sodium fluoride is not practically complete, determinations of the efficiency of the cell based upon the methods used by Ruff<sup>7</sup> or by Meyer and Sandow<sup>2</sup> will lack in accuracy. Argo, Mathers, Humiston and Anderson state that the current efficiency of their cell is about 70%, but they give no description whatsoever of the manner in which the yield of fluorine was determined. Simons assumes that the efficiency of his cell is the same as that designed by Argo. Bancroft and Jones give the efficiency as 30%, but with no experimental data.

There is also lacking in the literature any definite evidence as to the effect of impurities in the graphite anode or in the electrolyte,  $\text{KF}\cdot\text{HF}$ , upon the evolution of fluorine, two details that, as will be shown, have marked influence upon the operation of the cell.

With the thought of obtaining more precise information upon these several points, and of devising a cell that would be rugged, durable and simple in construction, that would operate without a diaphragm and that could be used intermittently over a considerable period of time, this investigation was taken up. The cell, which in its final form is described below, is the product of five years of study and gradual development. The first experimental tests of it were made in the Cornell Laboratory by W. I. Patnode. Later detailed investigation, both of the operation of the cell and of the preparation of the electrolyte, was carried on by J. M. Veeder three years ago. The construction of the cell in its present form, the study of its operation and the determination of its efficiency have been carried on by E. G. Rochow.

**The Cell.**—To permit of easy adjustment of the distance between the electrodes, and to lessen the probability of foaming, the cell is given the shape of a V (Fig. 1). It is constructed of heavy copper tubing which can be obtained on the market in the desired size. In the earlier cell this tubing was 30 mm. in internal diameter and the wall was 4 mm. thick. In the latest design the copper tube is the commercial, "heavy-duty" 2-inch pipe. The wall is about 5.5 mm. thick. The cell is made of two pieces of this heavy tubing, AA, each 30 cm. long, the lower ends of which are so cut that they can be joined at an angle of about 70°. They are brazed together at the junction. The temperature within the cell is measured by a thermometer, T, the bulb of which is inserted in a hole in a copper block that is brazed on the outside of the joint. This hole is filled with finely divided, metallic copper (copper bronze) to ensure good contact between the block and the thermometer.

The upper ends of the large copper tubes are threaded for about 40 mm. and are provided with heavy copper caps, BB, which are milled for a part of their length as

<sup>7</sup> Ruff, "Die Chemie des Fluors," p. 64.

<sup>8</sup> Moissan, "Das Fluor," translated by Zettel, p. 64.

shown, the upper part being of hexagonal shape. The hole through each cap is conical in shape and tapers from 18 mm. to 7 mm. The copper tubes C and D of 6 mm. internal diameter, screwed into the arms below the caps, serve as outlets for the gases evolved in the electrolysis. That on the cathode side C, is open to the air. The tube D on the anode side has at its outer end a flanged copper union E to which the left arm of the copper U-tube F is fastened by small screws as shown.

The two copper U-tubes, F and G, which were devised by us some six years ago, are filled with granular sodium fluoride to free the fluorine from hydrogen fluoride (see below). These are made of standard 9.5 cm. copper pipe and each tube is 17.5 cm. long and 9 cm. wide. The ends of the tubes are closed by conical copper plugs compressed by screw caps, which ensure gas-tight seals and protect the threads from the action of fluorine. The outlet tube, K, is threaded so that platinum delivery tubes of various shapes may be attached.

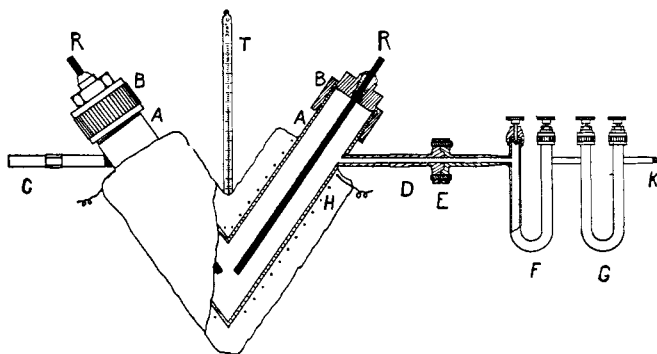

Fig. 1.

The two main arms of the cell are covered with asbestos paper nearly to the side-arms, C and D, and the two branches are then wound with 6 meters of chromel ribbon (0.733 ohm per foot). This ribbon is covered with a layer of asbestos cement, H, about 25 mm. thick. The winding is connected to a 110-volt a. c. circuit through a rheostat.

**The Electrodes.**—In our earlier experiments, in which the ordinary grade of Acheson graphite rods was used, the yield of fluorine was unaccountably low, and at times the evolution of the gas suddenly ceased after brief operation of the cell. Examination of the used anode rod showed that it had become coated with a glass-like layer. Spectroscopic analysis disclosed that this coating was high in silicon and that silicon was present in the graphite rods<sup>9</sup> or in the electrolyte, KF·HF, or in both. The silicon in the electrodes has been avoided by the use of Acheson graphite rods that have been twice baked to remove impurities. This is a grade that is made by that Company for use in spectroscopy. These rods, RR, are 5 mm. in diameter and 30 cm. long. The avoidance of silicon in the electrolyte will be mentioned under Electrolyte.

The graphite rods are inserted through the conical holes in the two caps and are held in position and insulated from the copper by means of Bakelite cement, which, after the carbons have been put in place, is hardened by baking it at about 125°. This cement (Trade Label, A.C. 6040) is easily applied and adheres very firmly to the graphite and the copper. It does not soften at the highest temperature that is here used, 300°.

<sup>9</sup> The photographs showed the presence of considerable amounts of vanadium, silicon and titanium, and traces of magnesium and calcium.

is an excellent insulator, and is quite resistant to the action of fluorine. The electrodes should, of course, be carefully centered.

Portland cement was found to be entirely unsuited for holding and insulating the graphite rods because it cracks when the copper is heated and cooled, and does not adhere well to the metal.

**The Electrolyte.**—Argo, Mathers, Humiston and Anderson prepared<sup>1</sup> the electrolyte,  $\text{KF}\cdot\text{HF}$ , and others either did so or used the commercial article. No careful examination of the purity of the salt or of the ratio of  $\text{KF}$  to  $\text{HF}$  seems to have been made.

We found that the low yield of fluorine persisted even after the purified graphite rods were employed, and that the anode rod still exhibited the glazed appearance after a run. Arc spectrum photographs were then made of the  $\text{KF}\cdot\text{HF}$  which had been purchased on the market, and it was found that the salt contained about 1% of silicon and 2% of magnesium. A supply of  $\text{KF}\cdot\text{HF}$  (Grade 01958), was then obtained from Schering-Kahlbaum, Berlin, and was found by spectroscopic test to be practically free from silicon and other impurities.

This salt was finely pulverized and was dried at about  $130^\circ$  for forty-eight hours. The ratio of  $\text{KF}$  to  $\text{HF}$  in it was then determined by heating samples in platinum crucibles to expel the hydrogen fluoride. Two analyses gave  $\text{KF}:\text{HF}$ , 1:0.9996 and 1:1.002. These results also demonstrate that the drying of the salt in the manner described above removes practically all of the moisture that it may have contained.

When the impure electrolyte was used and the salt was removed from the cell after a run of some hours, the discoloration of the  $\text{KF}\cdot\text{HF}$  showed that the inner walls of the cell had been seriously attacked during the electrolysis. With the pure electrolyte no such corrosion results. The salt is quite colorless when removed from the cell.

Lebeau and Damiens<sup>10</sup> employed  $\text{KF}\cdot 3\text{HF}$  because of its low melting point. This latter substance is objectionable because it is somewhat deliquescent, which makes necessary a preliminary electrolysis for the removal of the water each time before the evolution of fluorine begins. Although  $\text{KF}\cdot 3\text{HF}$  melts at a lower temperature than  $\text{KF}\cdot\text{HF}$ , that fact is of no value with the cell here described, because the temperature can easily be raised to the melting point of the latter compound.

Mathers has stated that with the cell which he and his associates devised, it is necessary to electrolyze the molten salt for several hours before fluorine is obtained. He adds, "It is hard to believe that water stays in the molten bath for that length of time, but I have no other explanation." The designers of other cells also mention the necessity of this long, preliminary electrolysis. Early experiments in this Laboratory by Mr. Patnode indicated that if  $\text{KF}\cdot\text{HF}$  is thoroughly dried, fluorine can be obtained in a relatively short time with its use. A thorough study of the electrolyte was then made by Mr. Veeder, with the object of ascertaining whether there is appreciable loss of hydrogen fluoride when the salt is dehydrated. He found that this loss is slight when the  $\text{KF}\cdot\text{HF}$  is dried at  $120^\circ$  for forty-eight hours, and that when the *pure* compound is fused and held slightly above its melting point (m. p.  $217^\circ$  determined by cooling-curve method) for thirty minutes, the loss amounts to only 0.8%. This confirms the statement<sup>7</sup> (p. 42) of Ruff. Meyer and Sandow<sup>2</sup> give the melting point of  $\text{KF}\cdot\text{HF}$  as  $227^\circ$  and state that it loses 1.077% of  $\text{HF}$  when heated for one hour at  $240^\circ$ , but this higher result is probably due to the presence of moisture in the salt after they had "well dried" it. When *pure*  $\text{KF}\cdot\text{HF}$  is thoroughly pulverized and is dried at about  $130^\circ$  for forty-eight hours, fluorine is evolved at once when the electrolyzing current is passed through the molten salt.

**Removal of Hydrogen Fluoride from Fluorine.**—Hydrogen fluoride escaping with

<sup>10</sup> Lebeau and Damiens, *Compt. rend.*, **181**, 917 (1925).

the fluorine may be removed by surrounding the copper U-tube F with a refrigerant (m. p. of HF,  $-83^{\circ}$ ;  $F_2$ ,  $-220^{\circ}$ ), but the method first suggested by Moissan of using potassium fluoride is the simpler. Sodium fluoride has since been employed by others as an absorbent for hydrogen fluoride, but we have found no description in the literature of any experiments upon the completeness of this removal. This was experimentally determined by generating about 500 cc. of hydrogen fluoride in a lead-lined copper tube by treatment of calcium fluoride with concentrated sulfuric acid, and carrying the gas by a current of air through the two copper U-tubes that had been freshly charged with granular sodium fluoride. From the tubes the gases passed through a platinum delivery tube into water. At the end of two hours, when the evolution of hydrogen fluoride was complete, the water into which the gas had been passed was found to contain only minute traces of acid, from which it follows that under the conditions of the experiment the removal of hydrogen fluoride from fluorine by passage of the gases through granular sodium fluoride is practically complete.

**The Electrolysis.**—The cell is charged with 1 kg. of pure  $KF \cdot HF$  (Schering-Kahlbaum) that has been thoroughly dried at about  $130^{\circ}$  for forty-eight hours. The heating current is then turned on and the salt is fused. This takes about forty-five minutes. The threads of the two caps, with the electrodes cemented into place in the manner already described, are dusted with powdered graphite, and the electrodes are introduced into the molten salt in the two arms. The caps are then screwed into place, and the outer ends of the graphite electrodes are connected to a 110-volt d. c. circuit through a rheostat and ammeter. For normal operation of the cell, the current is adjusted to about 5 amp. at 12 volts. If greater output of fluorine is desired, the current may be increased to 10 amp. at about 18 volts.

Fluorine issues from the arm of the cell immediately after the current is turned on. If the U-tubes containing the sodium fluoride are used, a few minutes must elapse before the air in the tubes has been swept out by the fluorine.

The operation of the cell may be stopped and renewed as desired, without removing the electrolyte, and subsequent electrolysis will yield fluorine as soon as the electrolyte has again been melted by the heating current. The  $KF \cdot HF$ , of course, gradually loses hydrogen fluoride with consequent rise of the melting point of the electrolyte. When this exceeds  $280^{\circ}$ , the caps are removed and the molten electrolyte is poured out. The cool cell is thoroughly washed with hot water and dried, and a new charge of the electrolyte is then introduced. It is inadvisable to attempt to regenerate the electrolyte by treatment with hydrofluoric acid; saving thus effected is but slight, and the pure salt can now be obtained on the market at a reasonable price.

If the electrolyte has not previously been freed from water, it is necessary to employ a current of high voltage (110 volts) at the beginning of the electrolysis to prevent polarization by the oxygen evolved at the anode. At a lower voltage this oxygen film on the anode rod prevents the passage of

the current. The long preliminary electrolysis that has been found by other investigators to be necessary before fluorine is evolved, is probably chiefly due to the water that is present in the electrolyte. Low yield of fluorine from the beginning or cessation of the evolution of the gas may, as has already been pointed out, be due to impurities in the graphite rods or in the electrolyte.

**Efficiency of the Cell.**—Various statements<sup>7,11</sup> have appeared in the literature concerning the efficiency of the cells that the authors employed, but only Ruff, and Meyer and Sandow give any details as to how this efficiency was determined.

Meyer and Sandow passed the fluorine first over sodium fluoride to remove the hydrogen fluoride, then over heated silicon, and finally passed the silicon tetrafluoride into a U-tube containing moist pumice. The amount of fluorine was calculated from the increase in weight of this tube. They give the yield as from 68 to 77.7% of the theoretical. They apparently did not ascertain the completeness of the removal of hydrogen fluoride by sodium fluoride, nor do they state the purity of the silicon which they employed.

Ruff used a similar method, passing the resulting silicon tetrafluoride through U-tubes containing moistened glass wool, soda-lime and calcium chloride. The yield of fluorine per ampere hour was then calculated from the weight of the silicon tetrafluoride obtained. The maximum efficiency that he gives was 31.5% with 5.4 amp.

Argo, Mathers, Humiston and Anderson state that their cell had a current efficiency of about 70%, but they do not say how they determined the yield of fluorine. Simons merely refers to the efficiency stated by Argo and his associates.

To ascertain the efficiency of the cell, it seemed desirable to use a more direct method than that in which the fluorine is passed over silicon, because of the doubtful purity of the silicon that is available. The presence of such elements as iron or magnesium, or the incomplete removal of hydrogen fluoride would seriously affect the accuracy of the results.

In the procedure that we finally adopted, the issuant gas was freed from hydrogen fluoride by sodium fluoride in the manner above described, and then was passed through a platinum delivery tube which was screwed into the exit arm of the second copper U-tube.

The percentage of fluorine in the issuant gas was then determined by two methods. (A) The gas was passed into a solution of potassium iodide and the free iodine was titrated. (B) The gas was passed into water and after any ozone that was set free had changed into oxygen, the oxygen was measured. In each case the electrolyzing current was held constant

<sup>11</sup> Argo, Mathers, Humiston and Anderson, *J. Phys. Chem.*, **23**, 353 (1919); Meyer and Sandow, *Ber.*, **54**, 766 (1921); Simons, *THIS JOURNAL*, **46**, 2178 (1924).

during the experiment and the time of passage was recorded. With a current of 5.2 amp., the current efficiency by method A was 45.5%, and by method B, 44%.

When the current was raised above 5 amp., the oxygen method was difficult to manipulate because of the rapid evolution of fluorine and the violence of its reaction with water. For that reason the iodine method alone was employed. The results are shown in Fig. 2.

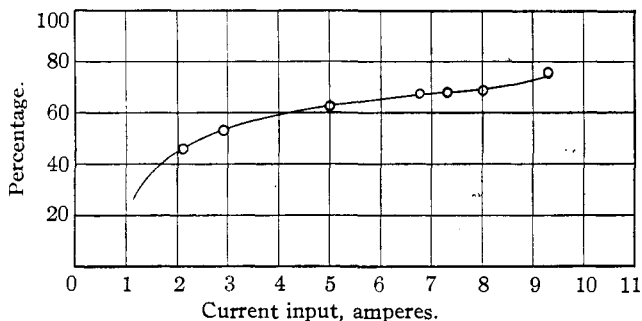

Fig. 2.

It will be seen that the current efficiency rises rapidly as the current is increased, reaching 76% at 9.3 amp. The output of fluorine is 0.92 liter per hour at 5 amp., and 2.88 liters per hour at 9.3 amp.

### Summary

The article contains a description of a rugged, durable copper cell, without diaphragm, for the production of fluorine. The completeness of the absorption of hydrogen fluoride by granular sodium fluoride, the effect of impurities in the graphite electrodes and in the electrolyte,  $\text{KF}\cdot\text{HF}$ , upon the operation of the cell and the yield of fluorine, and the current efficiency of the cell have been experimentally determined. The foaming of the electrolyte with consequent stoppage of the delivery tube, a difficulty reported in the operation of other cells, is avoided in this cell because the width of the copper tubes and the angle of the tubes facilitate the escape of the gas. It is shown that with pure graphite electrodes and a pure electrolyte that has been thoroughly dried, evolution of fluorine begins at once upon passage of the electrolyzing current. The cell can be used intermittently without removing the electrolyte, and its efficiency, determined by two simple methods, is about 76% with a current of 9.3 amp.